

E-JOIN

E-JOIN

EPS 伺服压装系统

集运动控制和检测评估
于一体的数字化压装单元

Digital press-mounting unit integrating
motion control and detection and evaluation

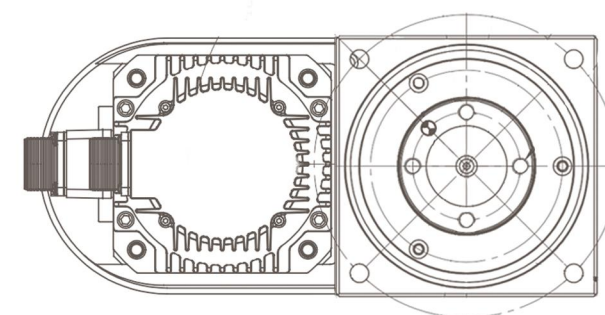
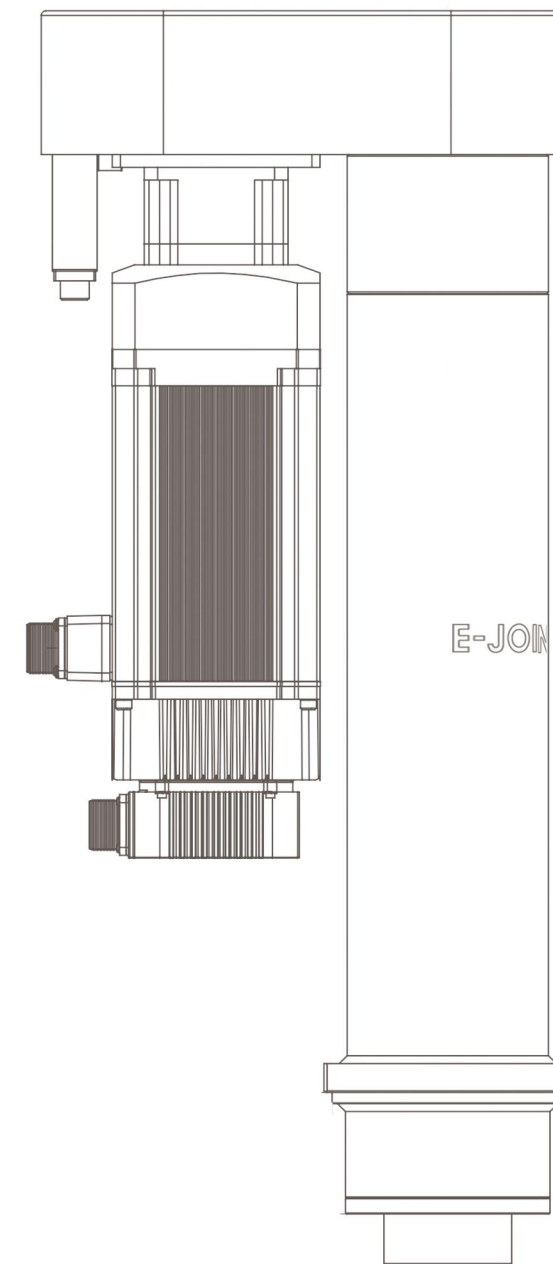

济南易久自动化技术有限公司
JINAN E-JOIN AUTO_TECHNOLOGY CO.,LTD

Add: 山东省济南市高新区新泺大街1166号奥盛大厦3号楼7层
7th Floor 3 Building No.1166 Xinluo Avenue Hi-Tech zone
Jinan Shandong Province,China

TEL: +86 531-62322819
Fax: +86 531-62322919
E-mail: sale@e-join.com.cn

成为持续领先的 装配技术提供商

To be a leading company
Assembly technology provider

公司介绍

COMPANY INTRODUCTION

济南易久自动化技术有限公司坐落于济南市东部高新技术开发区内，在上海、北京、广州、长春、武汉、重庆等城市设有办事机构及服务中心。我们是最早涉足电动伺服压装领域的中国企业，自主研发的EPS伺服压装系统源自汽车装配及在线检测领域的探索，注重产品+应用解决方案的深入研究，通过不断完善技术体系，为客户解决复杂的装配和测试任务。我们可以帮助客户制定工艺方案，规划设备配置，从工艺开发到产品试制，从最初试生产到最终量产，提供一站式的服务和设备解决方案。

我们与特斯拉、比亚迪、蜂巢传动、长安、大众、五菱、广汽、长城、小鹏、零跑、蔚来、一汽、重汽、柳工等国内外一流汽车厂建立了长期的合作关系，在专注汽车行业的同时，我们还为博格华纳、安道拓、潍柴、日本电装、美驰、爱科等世界知名企业提供自动化设备。主要业务涵盖整车、动力总成、汽车零部件、工程机械、家电、新能源、电子通讯、轨道交通等行业。

展望未来，易久自动化将大力推进智慧工厂相关技术的跟踪和研发，凝聚一支具备深厚行业背景及丰富实战经验的专业团队，依托自主开发的伺服压装系统，完美融合机器人、智能控制技术、智能图像识别及物联网智能科技，为客户构建高效节能、绿色环保的数字化工厂。

JINAN E-JOIN AUTO TECHNOLOGY CO.LTD is located in the east high-tech development zone of Jinan City, the company has offices and service centers in Shanghai, Beijing, Guangzhou, Changchun, Wuhan, Chongqing and other cities. We are the earliest Chinese enterprise involved in the field of electric servo pressing. Our self-developed EPS servo pressing system is derived from the exploration in the field of automobile assembly and online detection. We pay attention to the in-depth research of product+ application solutions, and solve complex assembly and testing tasks for customers by constantly improving the technical system. We can help customers to make process plans, plan equipment configuration, from process development to product trial production, from the initial trial production to the final mass production, to provide station service and equipment solutions.

We have established long-term cooperative relationships with first-class automobile manufacturers at home and abroad, such as Tesla, BYD, Honercomb Transmission, VW, Volkswagen, Liuzhou Wuling, GAC, Great Wall, Xpeng, Leapmotor, NIO, FAW-Volkswagen, Sina-Tnunk, LuGong, etc. While focusing on the automobile industry, we also provide automatic assembly equipment for BorgWarner, Adient, WEICHAI POWER, Denso, Mettler, Agoo and other well-known enterprises. The main business covers the whole vehicle, powertrain, auto parts, construction machinery, home appliance.

我们的业务范围 Our Business



伺服压装系统

Servo press mounting system

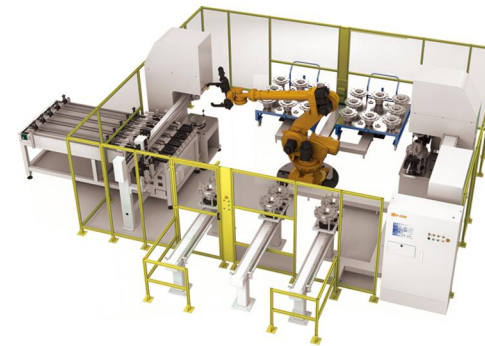

伺服压装解决方案

Servo press -mounting solution



压装周边功能模块

Press-mounting peripheral auxiliary module

伺服压装系统应用行业

SERVO PRESS FITTING SYSTEM APPLICATION

伺服压装系统应用行业

SERVO PRESS FITTING SYSTEM APPLICATION

汽车行业 >>

Auto industry



发动机: 连杆衬套、连杆销、轴承盖销、发动机缸盖阀座、缸盖导管、节温器、水泵、EGR阀等压装

Engine: connecting rod bushing, connecting rod pin, bearing cover pin, engine cylinder head seat, cylinder head conduit, thermostat, EGR valve, etc.



变速箱: 链轮轴承、拨叉衬套、空心定位销、密封圈等压装

Gearbox: sprocket bearings, fork bushing, hollow positioning pin, sealing ring, etc.



差速器: 轴承、复合衬套、油封等压装

Differential mechanism: bearing, compound bushing, oil seal, etc.



底盘系统: 转向节轴承、摆臂衬套、连杆衬套、转向节轮毂、副车架、助力转向系统 (EPS)、ABS阀等压装

Steering system: steering knuckle bearings, swing arm bushings, connecting rod bushings, steering knuckle wheels, etc.



轮毂相关: 轮毂轴承、齿圈、油封、螺栓等压装

Hub related: hub bearing, ring, oil seal, bolt etc.

新能源汽车 >>

New energy vehicle



电源系统: 电池模组焊接定位、电池托盘衬套压装

Power system: battery module welding positioning, battery tray bushing pressing



电驱系统: 驱动电机, 动力转向系统、机械转动装置、控制器、减速器等压装

Electric drive system: drive motor, power steering system, mechanical rotation device, controller, reducer and other pressure installation

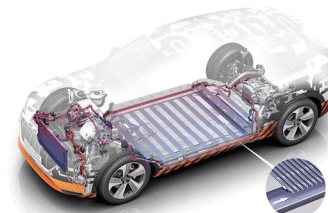

热管理系统: 水泵、油泵、电子水阀、温度传感器、温控器、压缩机、散热器等压装

Thermal management system: water pump, oil pump, electronic water valve, temperature sensor, thermostat, compressor, radiator

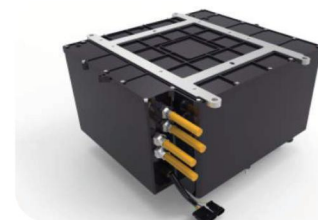

氢燃料电池: 氢燃料电池电堆压装

Hydrogen fuel cell: ressure mounting of hydrogen fuel cell stack



汽车电子: 激光雷达/毫米波雷达pin针压接、线束连接压接、传感器压接等

Automotive electronics: LiDAR/MMwave radar pin crimping, wire harness crimping, sensor crimping, etc

电机行业 >>

Motor industry

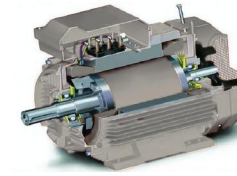

电机转子、电机轴承、电机轴承盖等压装

Motor rotor, motor bearing, motor bearing cover, etc.

轨道交通 >>

rail transit



停放制动缸压装

Press mounting of parking brake cylinder

军工行业 >>

Military industry



舵机零部件压装、点火器压装、阀芯等压装

Missile steering gear parts pressing, igniter pressing, valve core

医疗行业

Healthcare industry

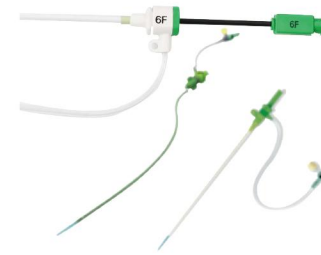

白色家电行业 >>

White appliance industry



正在发掘更多应用领域

More applications are being found

工艺应用 PROCESS APPLICATION

● 精密位控压装
Precision position control press fitting

压装位置精度达到 0.006mm，使用变形补偿算法精确控制压装位置。
Precision position control press fitting: press fitting positional accuracy requires to 0.006mm, the press fitting position is accurately controlled by using deformation compensation algorithm.

● 精确力控压装
Precise force-controlled press fitting

压装停止力要求小于 1%FS，配合不同速度实现精确的压装力控制。
the press fitting stop force requires to less than 1%FS to achieve accurate pressure control with different speeds.

● 柔性化密封装配
Flexible sealing assembly

柔性化完成压装工艺，对压装力进行区间监控，筛分不良品。
the press fitting process is flexibly complete, interval monitoring is carried out the pressure assembling force to screen defective products.

● 精密锁铆
Precision locking riveting

精确控制压铆位移及锁铆变形量，保证内部核心部件优良。
pressing rivet displacement and locking rivet deformation are accurately controlled to ensure the excellent internal core components.

● 齿圈装配
Geared ring assembly

倒角检测，精密完成齿圈压装及定位。
chamfering detection, precise completion of gear ring pressing and positioning.

● 压印成型
Coining molding

实时检测零件高度完成冲印成型。
real-time detection of part height to complete stamping molding.

● 折弯包边
Bending floding

完成折弯工艺，控制折弯卡扣形变。
complete bending process, control bending buckle deformation.

● 卡接
Clamping force

监控塑料件与金属件或插头公母头的卡接力。
monitor the clamping force between plastic parts and metal parts or plugs.



E-JOIN

EPS 伺服压装系统 EPS SERVO PRESS FITTING SYSTEM

伺服压装系统（简称：伺服压机，市场常用名：伺服压机、伺服压入系统、伺服压床）是集装配与测量于一体的数控压装单元，是实现“数字化装配”的核心部件。采用模块化伺服控制系统，实现力、位移、时间数据实时采集和分析，对装配过程中的力与位移、力与时间进行有效监测，适用于对工艺有严格要求的所有场合，如压装、成形、铆接、冲压以及弹性测试等高节拍、高精度的装配应用。

Servo press fitting system (referred to as: servo press, commonly known in the market: servo press, servo press in system, servo press) is a CNC press fitting unit integrating assembly and measurement, and is the core component to realize "digital assembly". The modular servo control system is adopted to realize the real-time acquisition and analysis of force, displacement and time data, and to effectively monitor the force and displacement, force and time in the assembly process. It is suitable for all occasions with strict requirements for press fit process, such as high beat and high precision assembly applications such as press fit, forming, riveting, stamping and elastic test.

产品优势 Product advantage:

- 操作简单 软件界面友好，操作简单，支持分支流程，多曲线显示及判定。
- 可靠耐用 机械刚性好，免维护设计，使用寿命 1200 万次以上。
- 安全环保节能 更高能源效率，相对于传统液压系统节省成本高达 80%，生产成本更低。
- 多控制模式精确度高 压力控制、位移控制、外接信号控制；压力精度 $\leq 1\%FS$ ，位置精度 $\leq 0.01mm$ 。
- 使用方便易于集成 一体化控制箱，防呆设计，航空插头；配套 10.4 吋监控仪和专用软件，易于集成，方便操作。
- Simple operation, friendly software interface, simple operation, support branch process, multi curve display and judgment.
- Reliable and durable, good mechanical rigidity, maintenance free design, service life more than 12 million times.
- Compared with the traditional hydraulic system, it can save up to 80% cost and lower production cost.
- The accuracy of multi control mode is higher than that of pressure control, satellite displacement control and external signal control; the pressure accuracy is less than 1% FS, and the position accuracy is 0.01mm.
- Easy to use, easy to integrate integrated control box, anti dazzle design, aviation plug; equipped with 10.4 inch monitor and special software, avoid secondary development, easy integration and convenient operation.

简练的控制——模块化和网络化 >> Succinct control — modularization and networking

模块化设计，本系统由伺服电缸、E-Press 工业软件、控制箱、监控仪和线缆模块五部分组成。控制箱实现伺服电缸的运行控制和压力数据采集，E-Press 工业软件内置标准数据库，完成力-位移的曲线实时显示、窗口判断和包络线检测。测量数据和装配结果可以与 PLC、服务器交互，满足过程数据的追溯要求。易久伺服压装系统可以非常灵活的集成在各种控制系统内，一台监控仪可以监控多套伺服电缸同时工作。

It uses modular design, the system consists of electronic servo cylinder, E-Press industrial software, control box, monitor module and cable module. The control cabinet realizes the parameter acquisition of servo cylinder operation control and pressure, built-in standard database for E-Press industrial software, and completes real-time display, window judgement and envelope line detection of force-distance curve. Data measurement and assembly results can interact with PLC, server in real time to meet the traceability requirements of process data. E-join servo press fitting system can be very flexible integrated in a variety of control systems, an industrial PC can control many electronic servo cylinder.

伺服压装系统拓扑图 Topology of servo press fit system

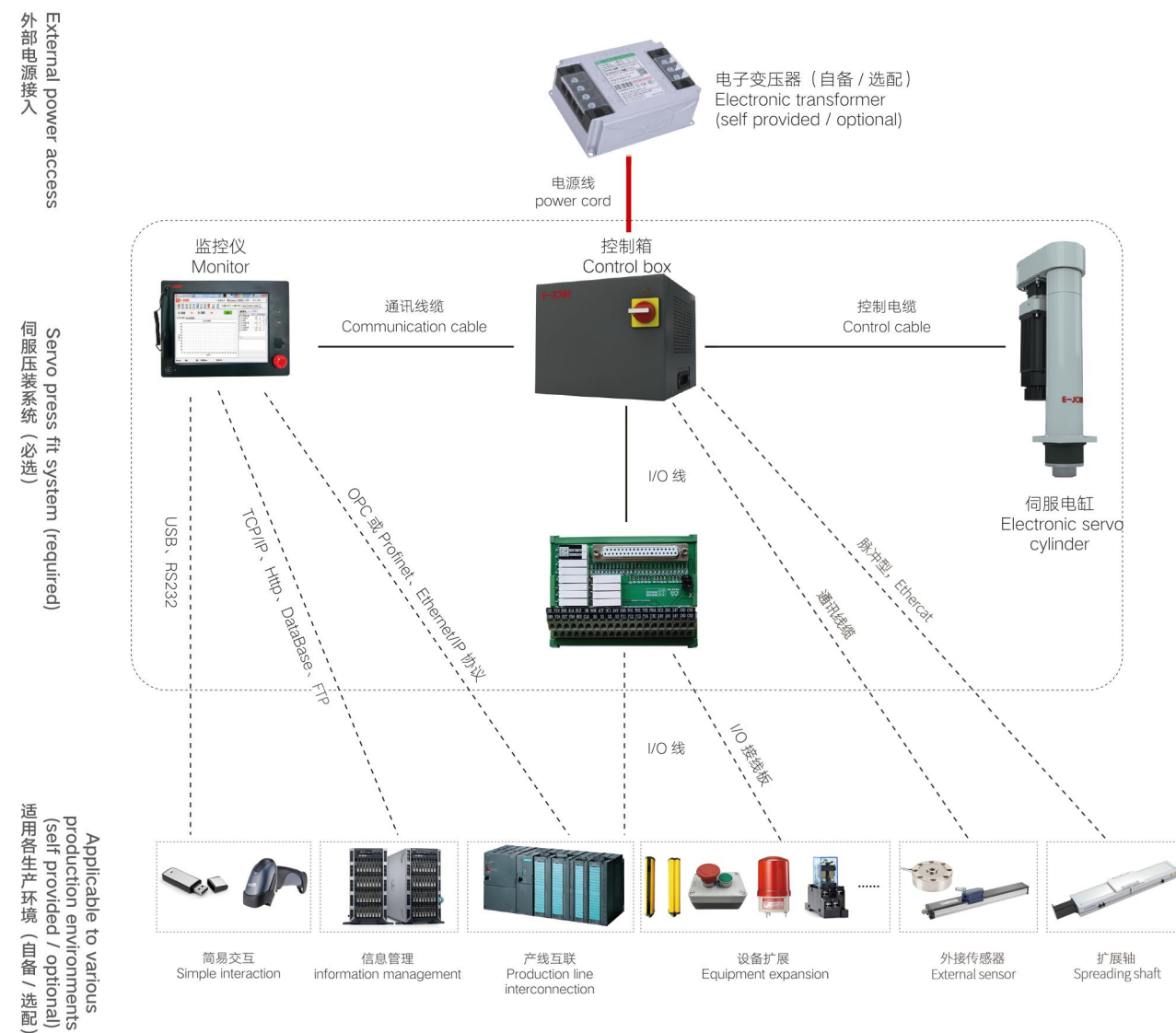

模块化应用 Modular application

易久伺服压装系统可以通过工业以太网或 I/O 实现与其它控制系统的交互。
E-join servo press fit system can interact with other control systems through industrial Ethernet or I / O.

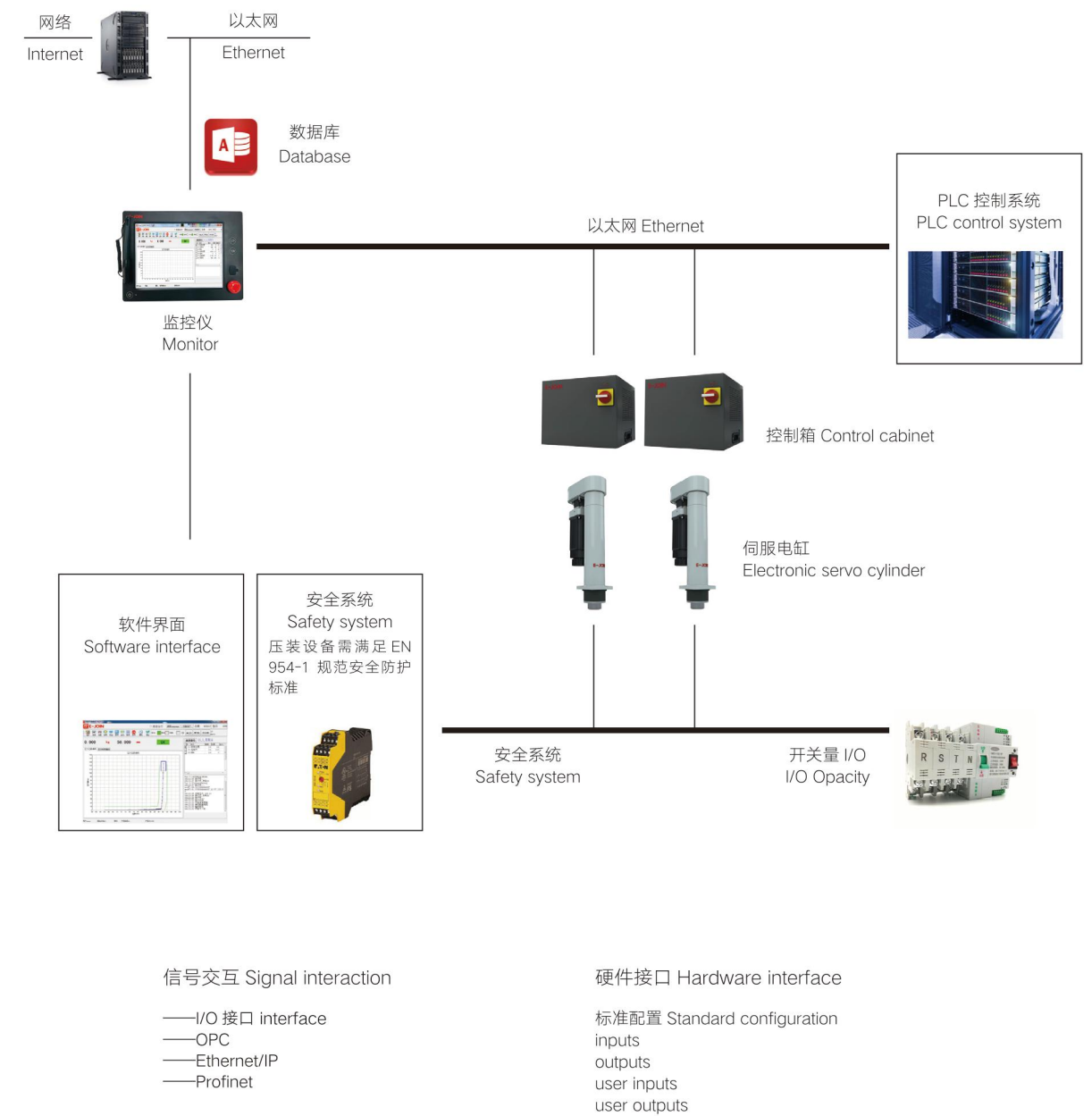

伺服压装系统 —— 产品系列

Servo motor pressing system >>

E-JOIN



N系列

压力: 2-350KN
行程: 100-600mm
最高速度: 50-260mm/s

该系列适用于大部分伺服压机应用场景, 推荐客户优先选用。

N series

Pressure: 2-350KN
Route: 100-600mm
Top speed: 50-260mm/s



P系列

压力: 5-200KN
行程: 100-400mm
最高速度: 60-130mm/s
保压时间: 不限

该系列适用于长时间保压的应用场景。

P series

Pressure: 5-200KN
Route: 100-400mm
Top speed: 60-130mm/s
Dwell time: Unlimited



H系列

压力: 1-5KN
行程: 100-200mm
最高速度: 400 mm/s
位置精度 (mm): ≤ 0.005 mm
力的控制精度 (KN): $\leq 0.5\%$ FS

该系列适用于精密装配、测试等应用场景, 可满足微米级的精度要求。

H series

Pressure: 1-5KN
Route: 100-200mm
Top speed: 400 mm/s
Position accuracy (mm): ≤ 0.005 mm
Control accuracy of force (KN): $\leq 0.5\%$ FS

N系列伺服压装系统

N series servo motor pressing system

规格 Specification	行程 (mm) Distance	最大压力 (KN) Maximum pressure	运行速度 (mm/s) Running speed	压力精度 Control accuracy of force	位置精度 (mm) Position accuracy
2KN	100-200	2	0.02-260	1%FS	0.01
5KN	100-200	5	0.02-260	1%FS	0.01
10KN	100-400	10	0.02-250	1%FS	0.01
20KN	100-400	20	0.02-125	1%FS	0.01
30KN	200-400	30	0.02-200	1%FS	0.01
50KN	200-400	50	0.02-200	1%FS	0.01
80KN	300-400	80	0.02-160	1%FS	0.01
100KN	300-400	100	0.02-140	1%FS	0.01
150KN	200-400	150	0.02-140	1%FS	0.01
200KN	200-400	200	0.02-100	1%FS	0.01
350KN	200-400	350	0.02-50	1%FS	0.01

备注: 行程可根据客户要求非标定制, 其它参数请咨询我方技术人员, 以便正确选型。

Note: the itinerary can be customized according to the customer's requirements. Please consult our technical personnel for correct selection.

N系列通用参数

N series General parameters

位置精度 (mm) Position accuracy (mm)	≤ 0.01 mm
力的控制精度 (KN) Control accuracy of force (KN)	$\leq 1\%$ FS
最大力保压时间 Maximum pressure retention time	3s
噪音 Noise	< 75dB
采集频率 Collection frequency	20KHZ
采集精度 Acquisition accuracy	24bit
寿命 (Time) Life (time)	> 1200 万次
防护等级 Protection level	IP54
总线方式 Bus mode	OPC, Ethernet/IP, Profinet
额定功率 (kW) Rated power (kw)	0.2-14.5KW, 50/60HZ
额定电压 (V) Rated voltage (V)	单相 220V、三相 220V 和三相 380V(产品不同、额定电压不同)
使用环境 Usage environment	0-50°C; 10-90%RH (无结露)
语言 language	CN/EN
输出格式 Output format	CSV/ xls

P系列伺服压装系统

P series servo motor pressing system

规格 Specification	行程 (mm) Distance	最大压力 (KN) Maximum pressure	运行速度 (mm/s) Running speed	压力精度 Control accuracy of force	位置精度 (mm) Position accuracy
5KN	100-200	5	0.02~130	1%FS	0.01
10KN	100-400	10	0.02~125	1%FS	0.01
30KN	200-400	30	0.02~100	1%FS	0.01
50KN	200-400	50	0.02~100	1%FS	0.01
100KN	300-400	100	0.02~90	1%FS	0.01
200KN	200-400	200	0.02~60	1%FS	0.01

备注：行程可根据客户要求非标定制，其它参数请咨询我方技术人员，以便正确选型。

Note: the itinerary can be customized according to the customer's requirements. Please consult our technical personnel for correct selection.

P系列通用参数

P series General parameters

位置精度 (mm) Position accuracy (mm)	≤ 0.01mm
力的控制精度 (KN)Control accuracy of force (KN)	≤ 1%FS
采集频率 Collection frequency	20KHZ
采集精度 Acquisition accuracy	24bit
最大力保压时间 Maximum pressure retention time	不限
噪音 Noise	< 75dB
寿命 (Time) Life (time)	> 1200 万次
防护等级 Protection level	IP54
总线方式 Bus mode	OPC, Ethernet/IP, Profinet
额定功率 (kW) Rated power (kw)	0.4~7.5KW, 50/60HZ
额定电压 (V)Rated voltage (V)	单相 220V、三相 220V 和三相 380V(产品不同、额定电压不同)
使用环境 Usage environment	0~50°C; 10~90%RH (无结露)
语言 language	CN/EN
输出格式 Output format	CSV/ xls

H系列伺服压装系统

H series servo motor pressing system

规格 Specification	行程 (mm) Distance	最大压力 (KN) Maximum pressure	运行速度 (mm/s) Running speed	压力精度 Control accuracy of force	位置精度 (mm) Position accuracy
1 KN	100-200	1	0.02~400	0.5%FS	0.005
2KN	100-200	2	0.02~400	0.5%FS	0.005
3KN	100-200	3	0.02~400	0.5%FS	0.005
5KN	100-200	5	0.02~400	0.5%FS	0.005

备注：行程可根据客户要求非标定制，其它参数请咨询我方技术人员，以便正确选型。

Note: the itinerary can be customized according to the customer's requirements. Please consult our technical personnel for correct selection.

H系列通用参数

H series General parameters

位置精度 (mm) Position accuracy (mm)	≤ 0.005 mm
力的控制精度 (KN)Control accuracy of force (KN)	≤ 0.5%FS
采集频率 Collection frequency	20KHZ
采集精度 Acquisition accuracy	24bit
最大力保压时间 Maximum pressure retention time	3 s
噪音 Noise	< 75dB
寿命 (Time) Life (time)	> 1200 万次
防护等级 Protection level	IP54
总线方式 Bus mode	OPC, Ethernet/IP, Profinet
额定功率 (kW) Rated power (kw)	0.2~0.75KW, 50/60HZ
额定电压 (V)Rated voltage (V)	单相 220V
使用环境 Usage environment	0~50°C; 10~90%RH (无结露)
语言 language	CN/EN
输出格式 Output format	CSV/ xls

伺服电缸——三大类型、十几种不同公称力范围的多用途伺服电缸 >>
Electronic servo cylinder— three types and more than ten kinds of multi-purpose electronic servo cylinder with different nominal force ranges

伺服电机通过传动机构与缸体内的滚珠丝杠连接，推动抗扭压杆直线运动完成压装过程，内置编码器对压装过程的位置数据采集和反馈。内置压力传感器实时采集压力数据，对压装过程进行压装力的记录和反馈。缸体的紧凑型设计，减少了缸体的安装高度。缸体内有坚固的抗扭压杆，其下侧可与压头直接连接。

The servo motor is connected with the ball screw in the cylinder block through the transmission mechanism to push the straight line motion of the anti-torsion rod to complete the pressing process. It is built-in strain pressure transducer to collect pressure size in real time, and carries out data recording and press fitting process feedback. The compact design of the cylinder block reduces the mounting height of the cylinder block. The cylinder block has a strong anti-torsion bar, which can be installed directly on the pressure head.

数控化设备简化辅助机械部分
Simplified auxiliary machinery for CNC equipment

- 高强度机械设计，确保长时间使用
- 原点定位和限位都是自有系统完成
- 压力传感器内置
- 抗扭压杆，可以直接安装压头工装
- High strength mechanical structure design to ensure long time use.
- The origin location and limit are done by the own system.
- It is built-in pressure sensor.
- It has an antitorque pressure bar, which can be directly installed tooling on the pressure head.

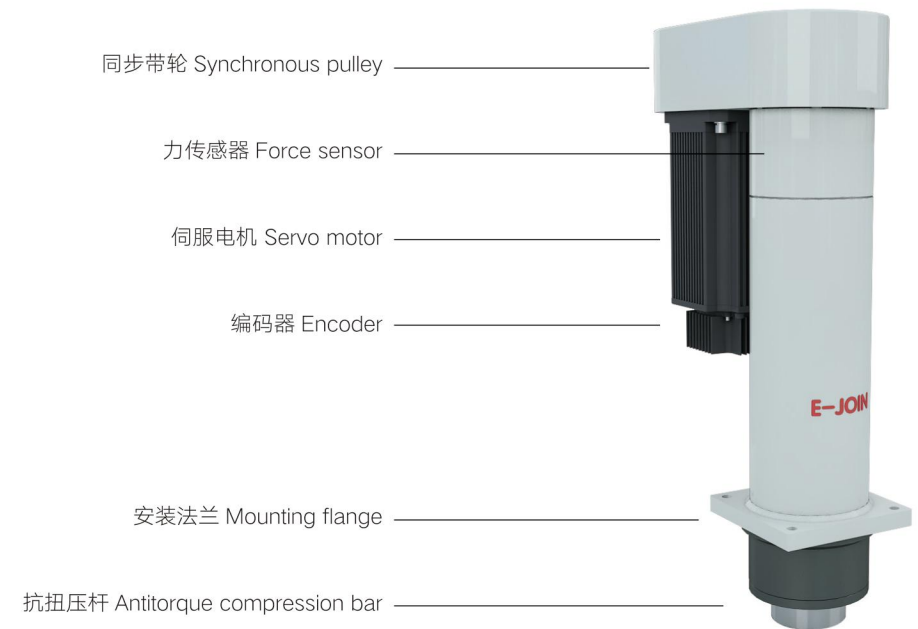

伺服电缸安装方式
Installation way of electronic servo cylinder

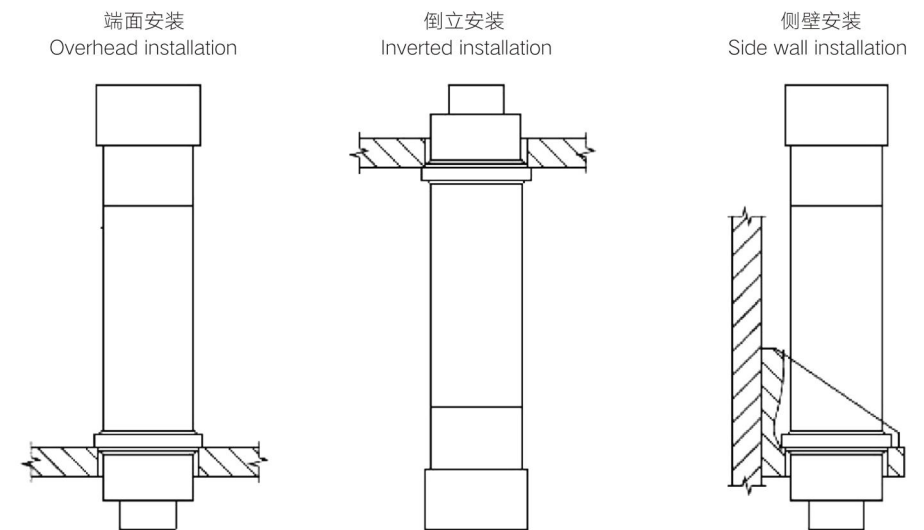

E-Press 工业软件——便捷直观的操作软件 >> E-Press industrial software —— convenient and intuitive operating software

软件基于 windows 平台，软件界面友好，操作简单，支持二次开发。实现压装工艺流程编制，压力位移曲线、压力时间曲线实时显示，一个工件多个压装步骤、多条压装曲线同时显示。支持判断窗口、包络线、测量等评估功能，输出 OK/NG 结果，用户等级化管理可以设置不同权限，压装历史记录、操作日志、报警日志方便查询。E-Press 工业软件支持 MS SQL、Access 等主流数据库格式。

The software is based on Windows platform, with friendly interface, simple operation and supporting secondary development. Realize the compilation of press fitting process flow, real-time display of pressure displacement curve and pressure time curve, support multiple press fitting curves, support judgment window, envelope line, measurement and other evaluation functions, output OK / ng results, user hierarchical management can set different permissions, press fitting history record, operation log and alarm log for easy query. E-Press industrial software supports mainstream database formats such as MS SQL and access, and provides many interfaces for communication with peripheral devices.

界面友好 易于操作
Friendly interface, easy to operate

便捷编程模式，仅需输入相应参数
Convenient programming mode, just input the corresponding parameters

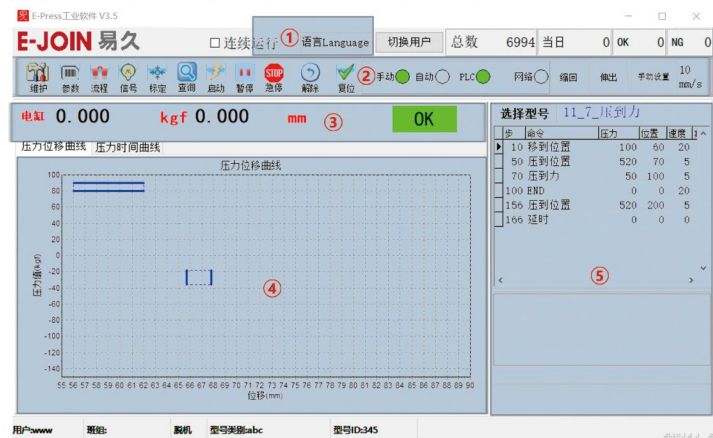

- ①中英文一键切换
- ②设备管理区
- ③当前状态显示
- ④过程监控区
- ⑤状态信息区

对每一个压装过程 进行 100% 实时检测
100% real-time detection of each press fitting process

显示力与位移的曲线，根据设定条件进行评估，给出 OK/NG 结果
A curve showing force and displacement is evaluated according to the setting conditions to give OK/NG results

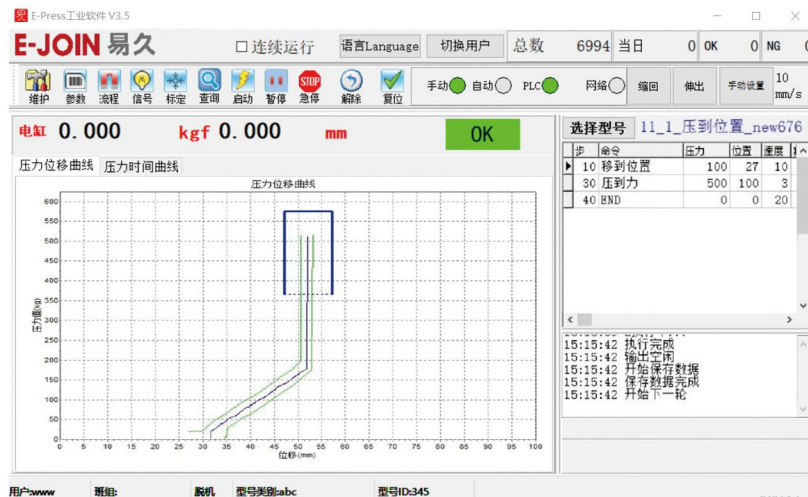

内置检测程序丰富 满足所有压装要求
Rich in built-in detection program and meet almost all press fitting

窗口检测 Window detection
包络线检测 Envelope curve monitoring
测量自定义 Custom measurement

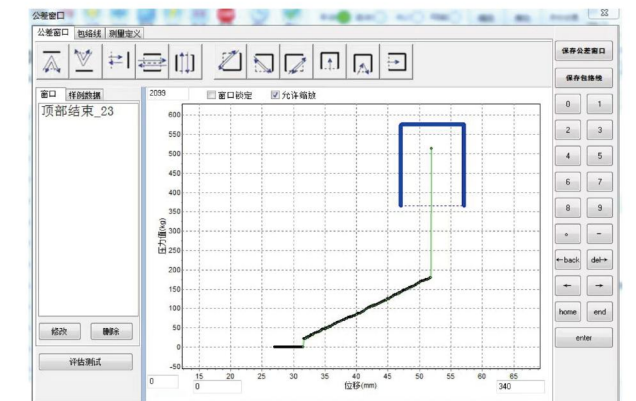
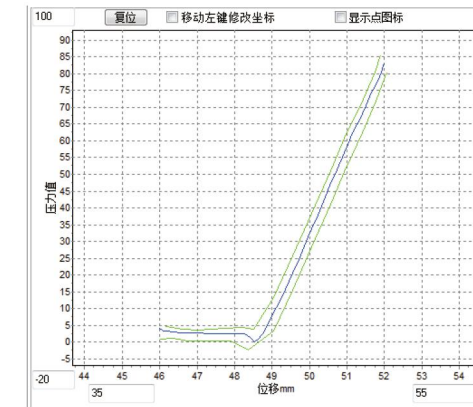
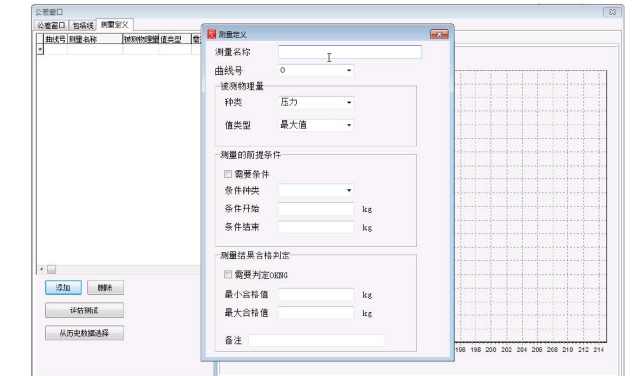

数据存储与查询
Data storage and query

可保存500万条以上的压装曲线，查询提供多种数据检索方式。
Can save more than 5 million pressing curves, query to provide a variety of data retrieval methods.

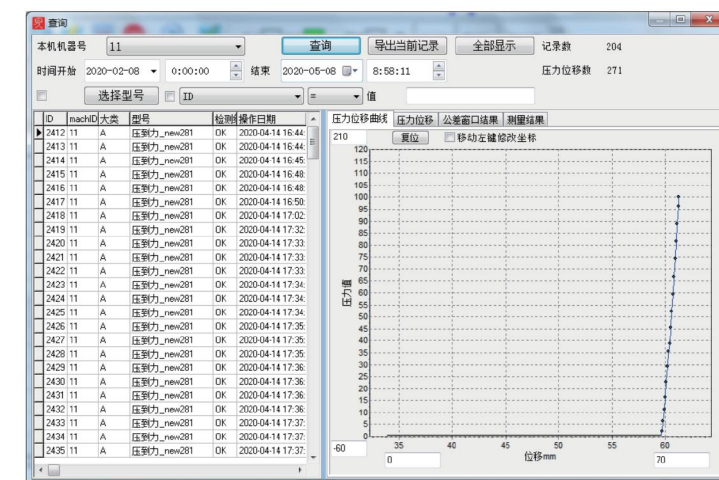

支持压装中实时生成或者查询界面导出CSV、EXCEL格式的数据文件。亦可将数据文件实时上传到用户采集系统。可离线显示csv曲线，单次可显示2000条。

Data files in CSV and EXCEL formats can be generated in real time during pressing or exported on the query interface. Data files can also be uploaded to the user acquisition system in real time.

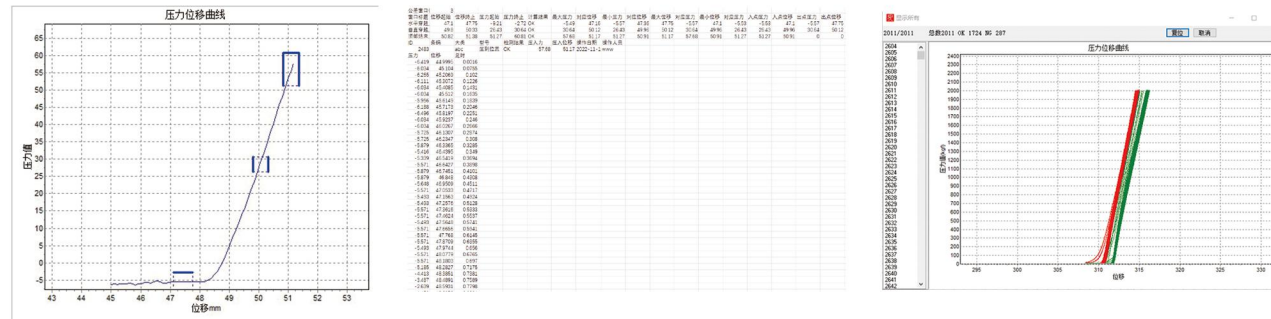

支持一工件多个压装步骤多条压装曲线记录、窗口判形
Support one workpiece multi-pressing step multi-pressing curve record, window shape

自动工装换型，实现一台压机完成多种零部件装配，让复杂压装控制成为简单操作。
Automatic tooling change, to achieve a press to complete a variety of parts assembly, so that complex press assembly control becomes simple operation.

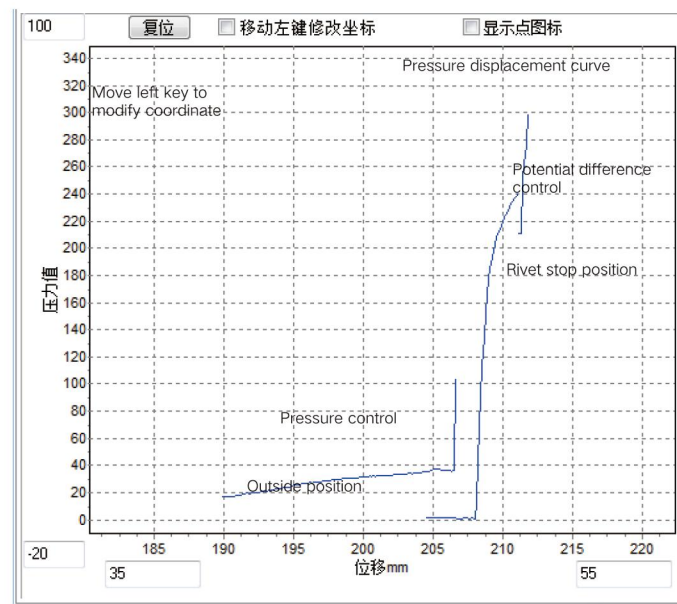

控制箱 >> Control cabinet

控制箱将伺服运动控制、压力检测、IO接口、滤波、电源等一体化设计，解决了干扰、粉尘、散热等问题，维护性高、稳定性好，线缆接口防呆设计、全部采用插头方式，连接方便。

The control cabinet is integrated designed the servo motion control, pressure detection, IO interface, filtering, power supply to servo motion control, pressure detection, IO interface, filtering, power supply and other integrated design problems, with high maintenance, good stability, cable interface error-proof design. All use plug mode, which is easy to connect.



接口定义
Interface definition

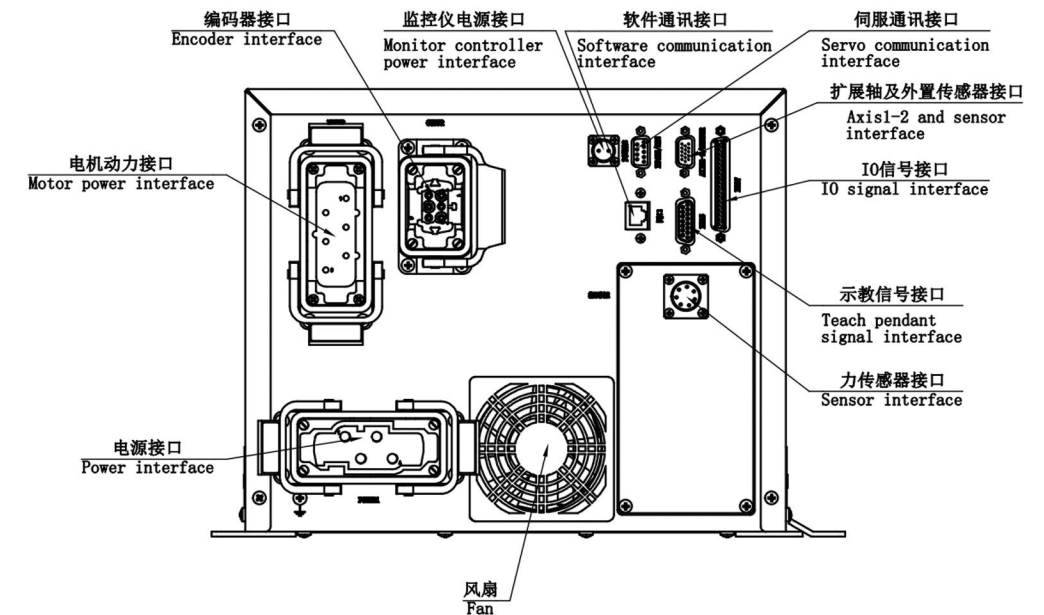

安装方法
Installation diagram

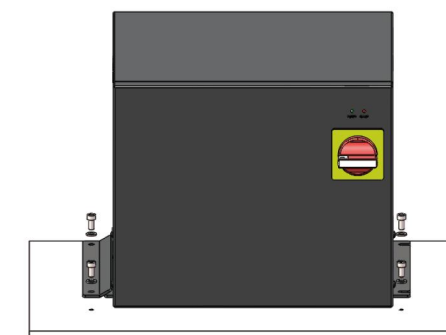

外部 IO 信号 External IO signal

伺服压装系统具有 14 个输入信号和 12 个输出信号的外部 I/O 接口，其中可编程的为 4 个输入和 4 个输出信号。

The servo press mounting system has 14 input signals and 12 output signals external I/O interfaces, among which 4 input signals and 4 output signals are programmable.

For the convenience of customer wiring and signal isolation, we designed IO terminal block. The input signal on the IO terminal block is photoelectric isolation signal and the input signal is relay signal.

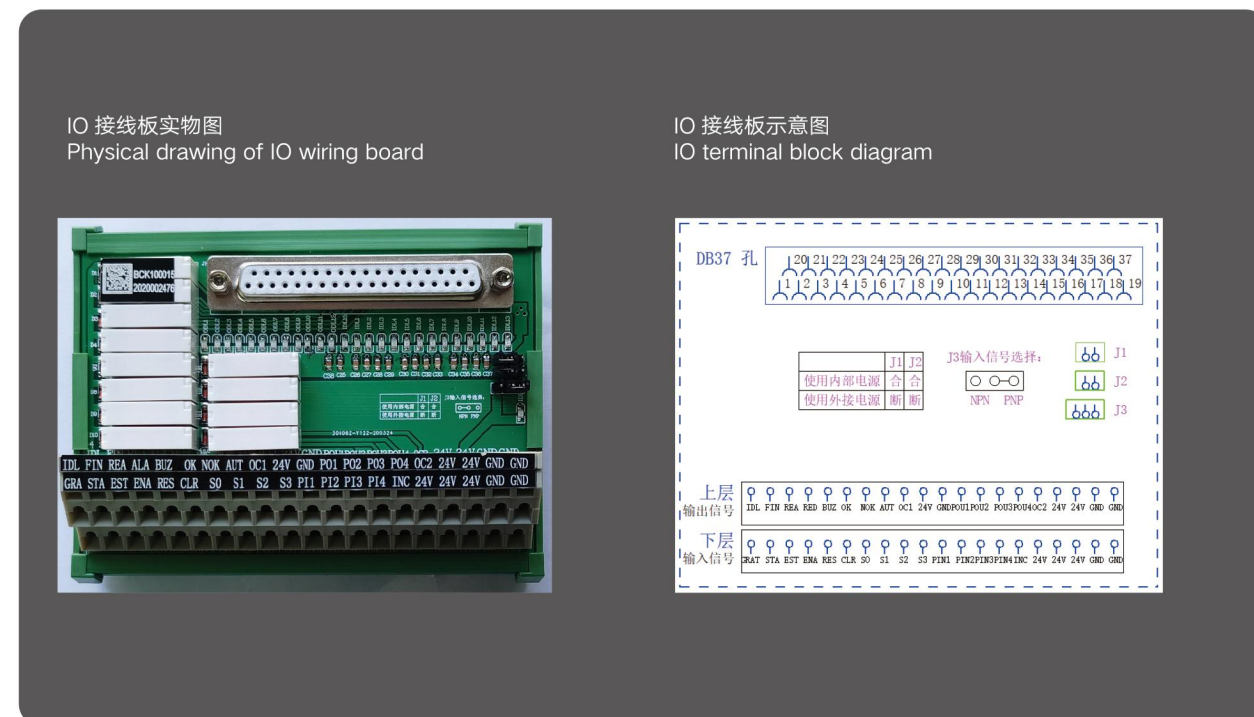

监控仪 >> Monitor

监控仪是用户完成工艺编写、过程监控、记录查询、报警或日志详细信息查询的窗口，无需键盘鼠标外设可以通过触摸屏完成全部操作。同时单机提供手动运动示教功能，支持软、硬急停。可选择面板嵌入安装、摆臂安装，侧壁安装，三种任意方式。

The monitor is the operation equipment that the customer completes the process writing, process monitoring, record inquiry, alarm or log detailed information inquiry, and does not need the keyboard mouse peripheral device to complete the entire operation through the touch screen. Meanwhile, the single machine provides manual motion teaching function, and it supports software, hardware and urgent stop.



接口定义 Interface definition

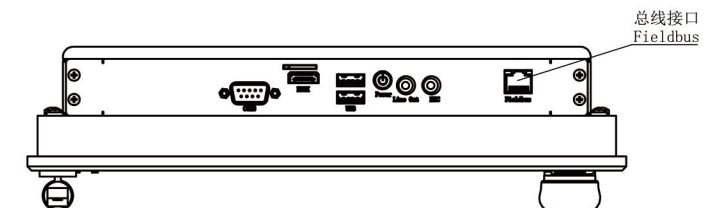
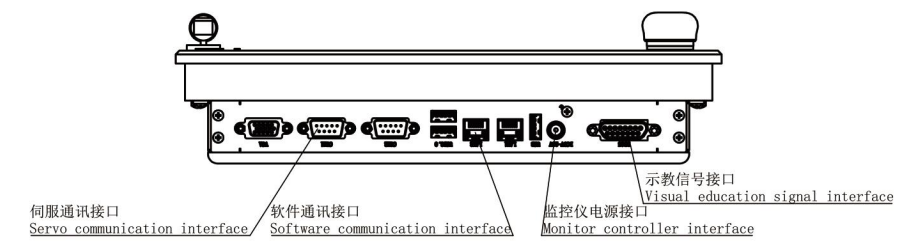

外形尺寸 boundary dimension

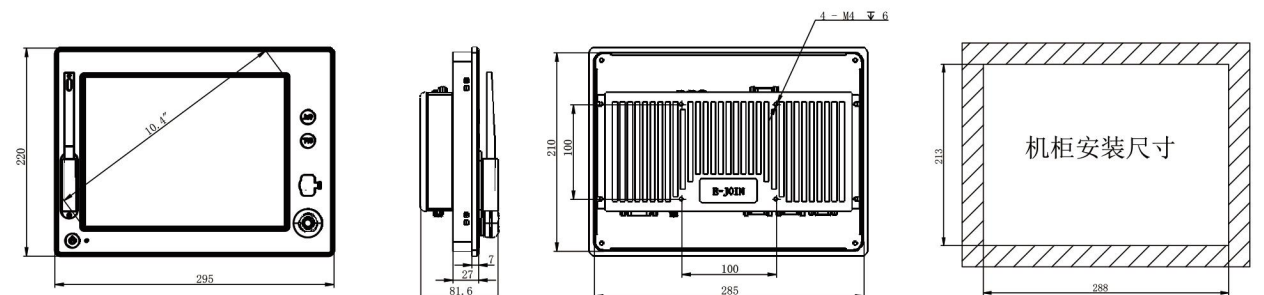

压力校准仪 >> Pressure calibrator

产品简介 Introduction

压力校准仪，是为校验各种压力变送器、压力传感器、压力开关、差压变送器、数字压力表、专用压力校验仪器。易久压力校准仪是为了校准 EPS 伺服压装系统而研制的一款智能化仪表，采用高精度力传感器，性能稳定可靠。可应用于材料性能测试，电阻应变式传感器的检测等多种工业行业。易久压力校准仪整套已经过专业部门标定、铅封。量程：0-400KN，精度：±0.03%FS。

Pressure calibrator is used to calibrate various pressure transmitters, pressure sensors, pressure switches, differential pressure transmitters, digital pressure gauges, and special pressure calibration instruments. E-JOIN Pressure Calibrator is an intelligent instrument developed for calibrating EPS servo press-fitting system. It adopts high-precision force sensor with stable and reliable performance. It can be applied to various industrial industries such as material performance testing, peak measurement, and resistance strain sensor detection, and is an industrial-grade instrument. The complete set of E-JOIN Pressure Calibrator has been calibrated and sealed by professional departments. Range: 0-400KN, accuracy: ±0.03%FS.



定心模块 >> Relocatable module

产品简介 Product profile

- 定义：用于过盈装配中工装的角度和位置导正的装置。
- 原理：内部的弹性机构在装配倒角的作用下可以发生角向或者平移，压装完成后可重新复位。
- 作用：提高一次性装配合格率、缩短设备调整周期、延长生产设备及工装的使用寿命。
- 应用背景：因产品、设备、工装等因素不能保证零件与压入孔中心同轴，压装过程容易出现工件划伤、挤压变形、磨损等现象。
- 应用场景：轴承、油封、衬套等精密压装场合，可配合易久伺服压装系统使用，安装孔与伺服电缸兼容。
- Definition: it is used for angle and position compensation of tooling in interference assembly.
- Principle: the internal elastic mechanism can be angled or shifted under the action of assembly chamfering, and reset after pressing.
- Function: improve the qualified rate of one-time assembly, shorten the adjustment period of equipment, and prolong the service life of production equipment and tooling.
- Application background: because the product, equipment, tooling and other factors can not ensure that the parts are coaxial with the center of the pressing hole, the process of pressing is prone to the phenomenon of workpiece scratch, extrusion deformation, wear and so on.
- Application scenarios: precision pressing occasions, such as bearing, oil seal, bushing, etc., can be used Yi Jiu servo press system, is compatible with the mounting hole and electrohydraulic servo cylinder.

定心模块型号

Model of the centering module

名称	型号	描述
10KN 角向定心模块	EACM-10	竖直使用，可安装在压头上或者下工装上。
30KN 角向定心模块	EACM-30	
50KN 角向定心模块	EACM-50	
100KN 角向定心模块	EACM-100	
10KN 全向定心模块	EOCM-10	竖直使用，可安装在压头上或者下工装上。
30KN 全向定心模块	EOCM-30	
50KN 全向定心模块	EOCM-50	
100KN 全向定心模块	EOCM-100	

备注：角向定心模块仅能满足和实现角度偏移，全向浮动既能满足和实现角度偏移也可做水平偏移。

安装示意

Installation schematic diagram

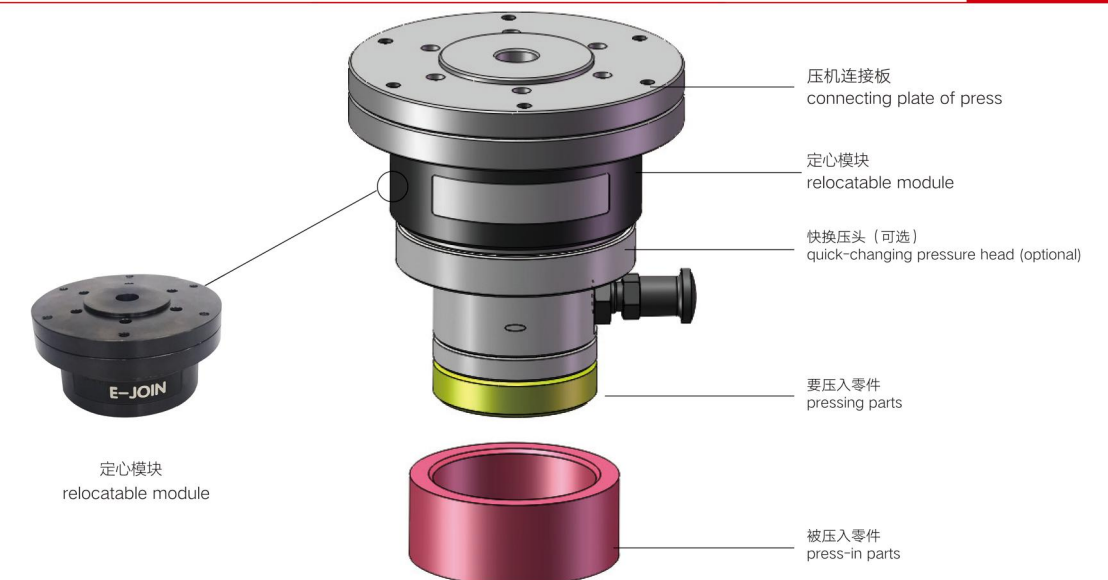

标准机体模块 >> Standard body module

产品简介 Introduction

定义：用于固定装配零件的工装与伺服电缸的装置。

原理：通过金属的连接构件，保证在额定的压装力范围内具有良好的刚性。

作用：可提高高压装设备的装配效率和高质量要求。

应用背景：配合伺服压机调试使用，提高集成效率；模块化批量制作，成本优势明显。

Definition: a device used to fix the tooling and servo cylinder of assembly parts.

Principle: through the metal connection components, to ensure good rigidity within the rated press mounting force range.

Function: it can improve the assembly efficiency and high quality requirements of press fit equipment.

Application scenarios: bearings, oil seals, bushings and other press fit occasions can be used with the servo press fit system of Yijiu, and the mounting holes are compatible with the servo cylinder.



C型台式机体

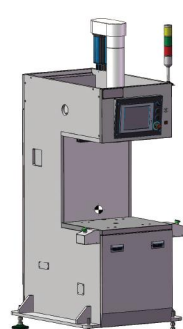

C型落地式机体

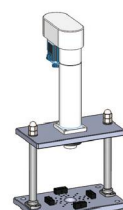

两柱式机体

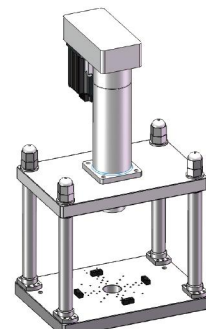

四柱式机体

标准机体模块型号 Standard body module model

机体分类	最大承载	型号	描述
C型台式机体	5KN	ESCM-05	C型结构，便于取放料，底部设计定位孔和螺栓孔，可配合不同工装使用，适合单机或者全自动压装装配设备。
	10KN	ESCM-10	
C型落地式机体	30KN	ESCM-30	
	50KN	ESCM-50	
	100KN	ESCM-100	
两柱式机体	5KN	ESPM-05	
	10KN	ESPM-10	
四柱式机体	30KN	ESPM-30	
	50KN	ESPM-50	
	100KN	ESPM-100	

注：以上为我司标准备货产品，也可根据客户需求非标设计制造各种特殊规格。

运输包装 >> Transport packaging

济南易久提供的伺服压装系统必须经过测试校准、老化检验合格后妥善包装方可出厂。按照随机文档，客户可以便捷开通设备。随机文档包括：合格证、保修卡、设备说明书、装箱清单。

The servo press mounting system provided by E-JOIN code must be tested, calibrated, aged and properly packaged before leaving the factory. According to the attached documents, customers can easily open the equipment. The accompanying documents include: certificate, warranty card, equipment instruction and packing list.



OUR SERVICES

我们的服务 >> Our services

E-JOIN

EPS 伺服压装系统源自汽车装配及在线检测领域的探索，注重产品 + 应用解决方案的深入研究，通过不断完善技术体系，为客户解决复杂的装配和测试任务。我们可以帮助客户制定工艺方案，规划设备配置，从工艺开发到产品试制，从最初试生产到最终量产，提供一站式的服务和设备解决方案。

EPS servo press fitting system originates from the exploration in the field of automobile assembly and on-line inspection, pays attention to the deep research of product + application solutions, and solves the complex assembly and testing tasks for customers by continuously perfecting the technical system. We have a group of experienced and skilled engineers who can help customers to make process plans, plan equipment configuration, and provide one-stop service and equipment solutions from process development to trial production, and from initial trial production to final mass production.

我们的服务包括 Our services include

- 工艺开发（工件压力估算、压装流程制定、压装过程检测标准制定、工件判型、上下料及筛分工艺等）。
- 试压工件（按客户工艺要求试压工件，出具试压报告或视频）
- 租赁（租用我方设备或客户小批压装服务）
- 安装（我方安装设备就位服务，独立试运行）
- 培训（设备使用方法培训、常见报警培训、信号培训）
- 本地和远程技术支持。
- 标定校准服务。
- 紧急维修或备机服务。
- 备件服务。
- Process development (work-piece pressure estimation, press-up process formulation, press-up process testing standard formulation, work-piece shape, loading and unloading and screening process, etc.).
- Pressure test workpiece (pressure test workpiece is made according to customer's process requirement, and it should be issued the test report or video)
- Lease(hire our equipment or customer outfitting service)
- Installation (installation equipment in place service, independent trial operation)
- Training (training in the use of equipment, common alarm training, signal training)
- Local and remote technical support.
- Calibration services.
- Emergency maintenance or standby service.
- Spare part service.



易久在全国有6个办事处，1个服务中心，为您提供全方位不间断的服务支持，保证您生产无忧。
E-join has 6 offices and 1 service center nationwide, providing comprehensive and uninterrupted service and support to ensure worry-free production for our customers.



E-JOIN



典型客户 Typical customers

全球 500 多家客户 有汽车的地方就有易久
More than 500 customers around the world have cars, there are E-join.

